

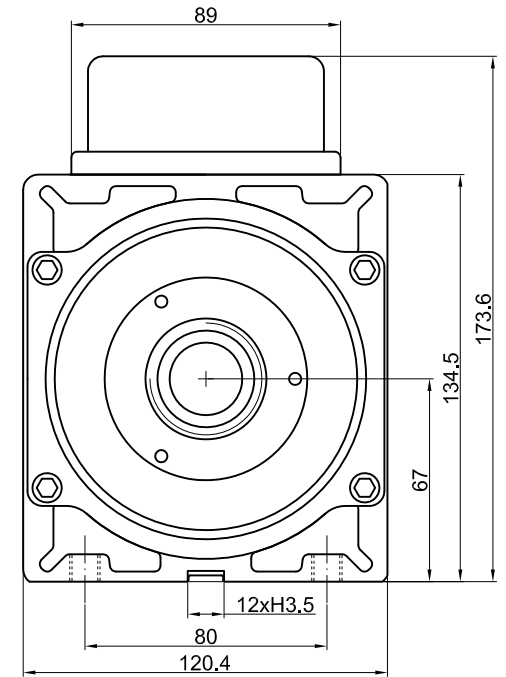

# ELECTROSPINDLE C60/67

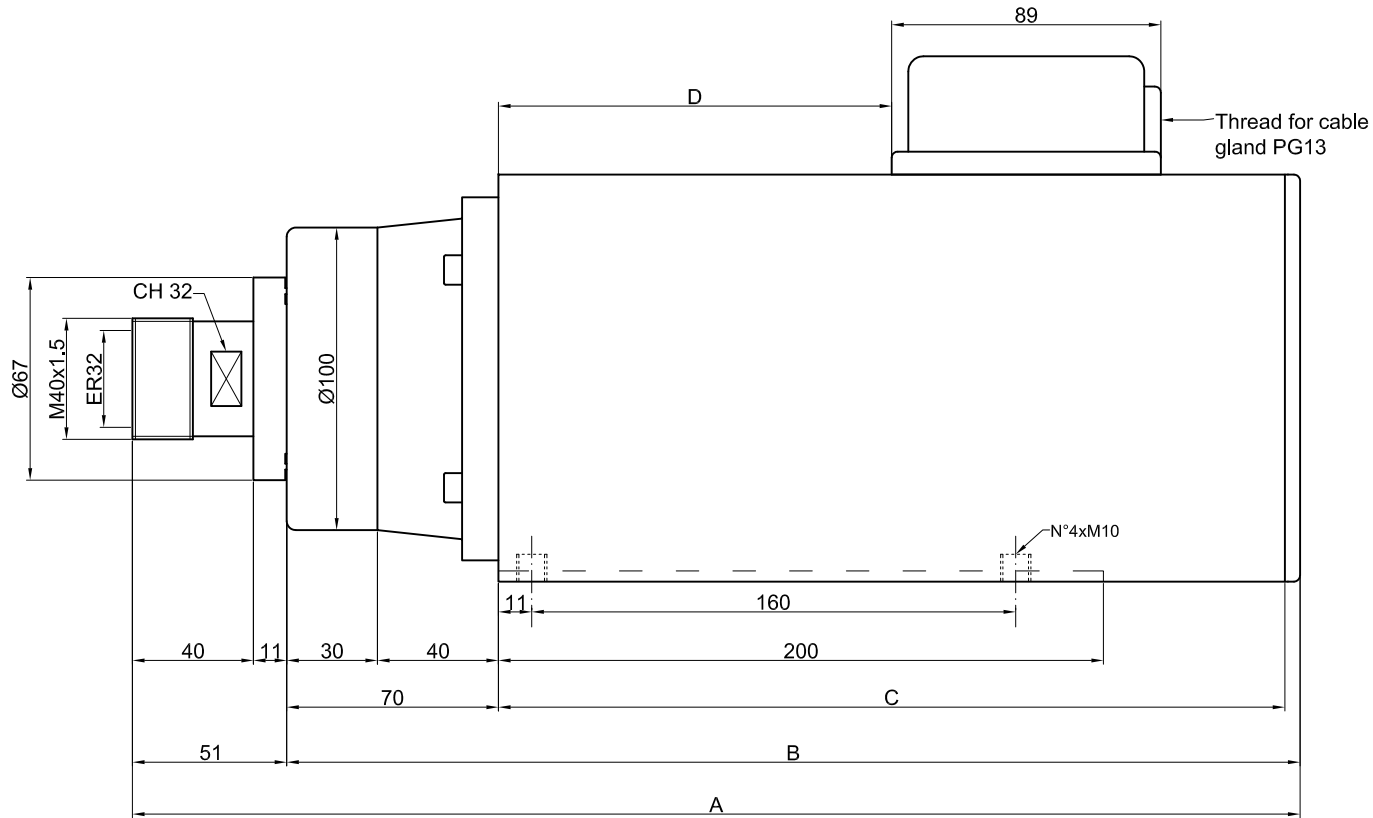

Standard fixing holes on terminal board opposite side.  
 Fixing holes on other sides on demand.  
 Collets, nuts and wrenches only on demand.

TYPE	OVERALL DIMENSION (mm)				POWER CHARACTERISTICS			
	A	B	C	D	Hz	kW	V	A
6067 A	346	295	220	90	100	1,9	220 / 380	7.55 / 4.35
					200	3,0	220 / 380	12.3 / 7.10
					300	4,5	220 / 380	18.0 / 10.0
					400	4,5	220 / 380	18.0 / 10.0
6067 D	386	335	260	130	100	3,3	220 / 380	12.8 / 7.4
					200	4,5	220 / 380	18.2 / 10.6
					300	7,0	220 / 380	25.0 / 14.5
					400	7,0	220 / 380	25.0 / 14.5

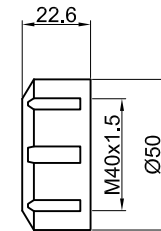

Nut GT 32

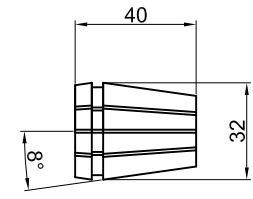

Collet ER 32  
 Ømin-max 2-20mm

*The electrospindle C60/67 can be equiped even with ER40 shaft end.*